

Perspektive
Schloss:

T-FF1662 .../D 92/... M2

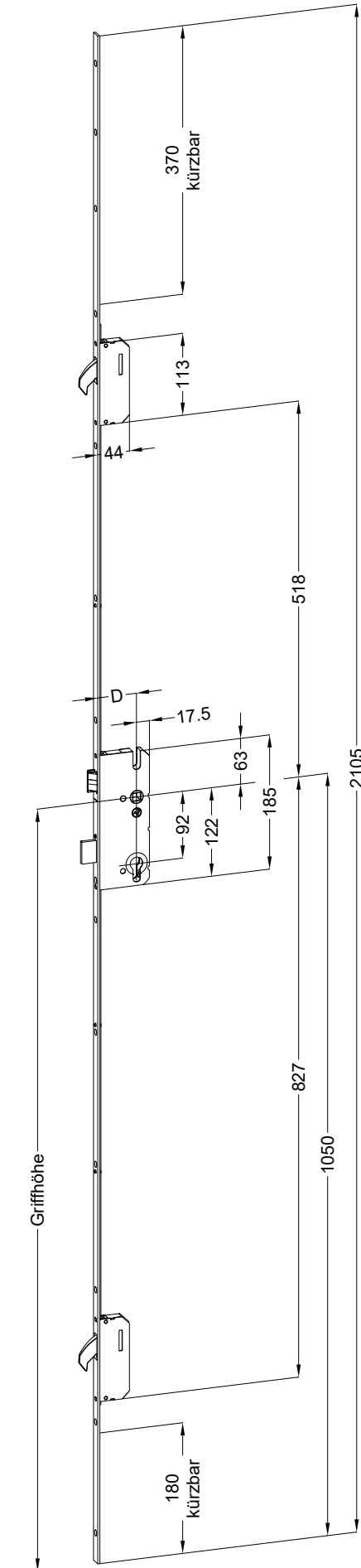

Schraublage
Schloss:

T-FF1662 .../D 92/... M2

Technische Änderungen vorbehalten!

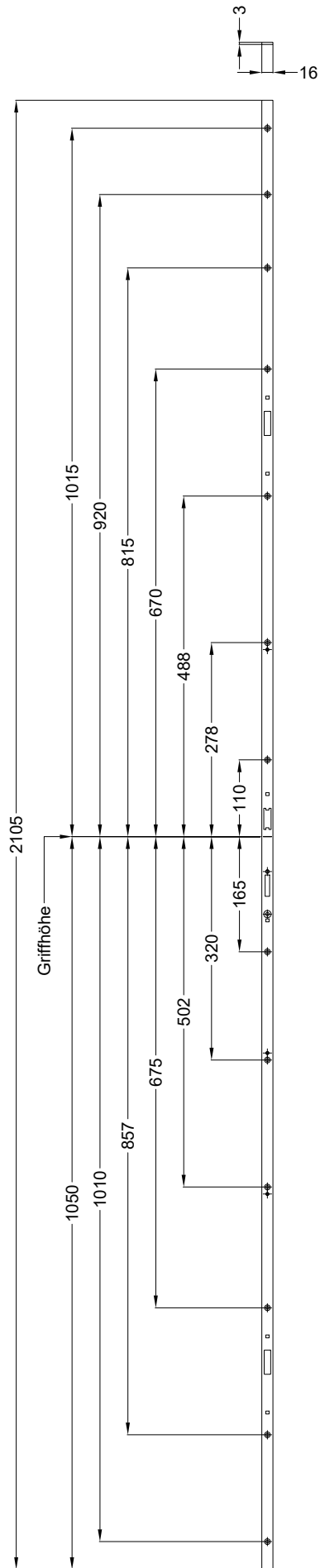

Ansichten
Schloss:

T-FF1662 .../D 92/... M2

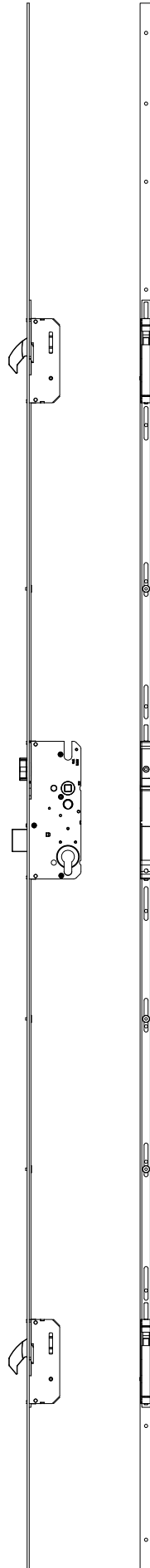

Technische Änderungen vorbehalten!

Fräsmaße
Schloss:

T-FF1662 .../D 92/... M2

Empfohlene Fräsung

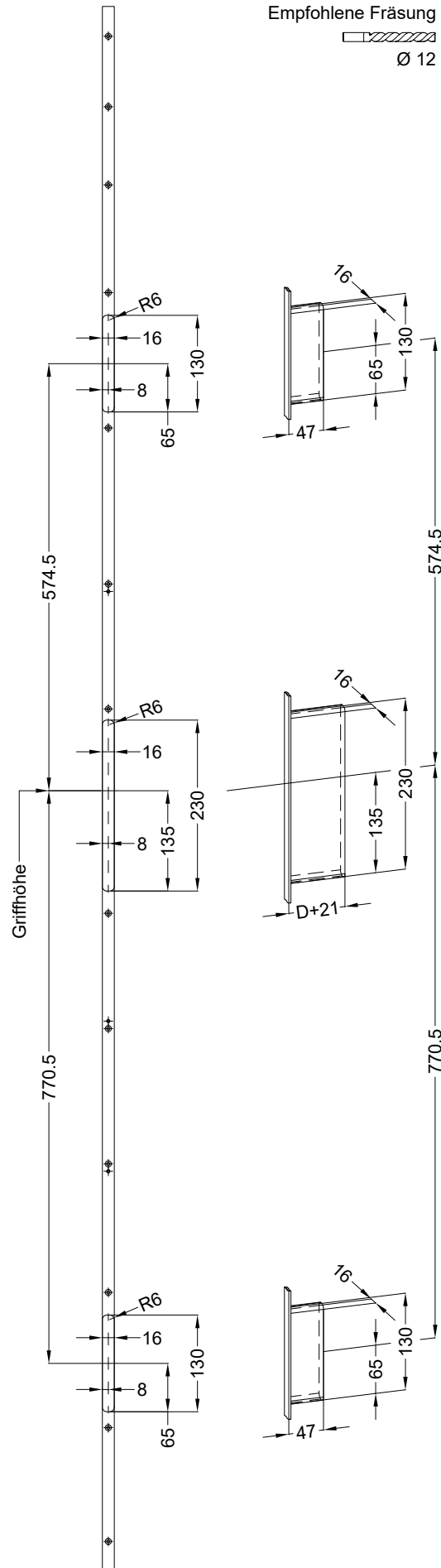
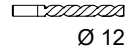

Einbausituationen der Bauteile mit Fräsmaßen

Schloss: T-FF1662 .../D 92/... M2

Allgemeine Vermaung

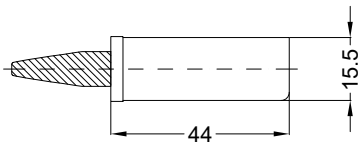

Frsmae

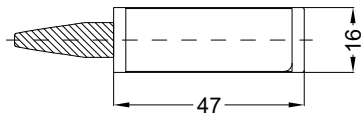

Situation
Schwenkriegel

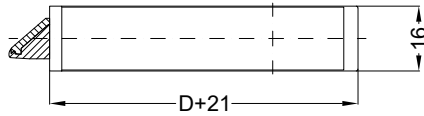
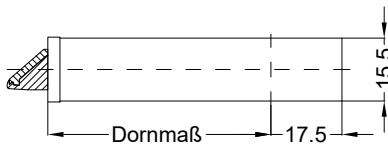

Situation
Falle

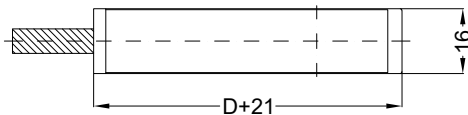
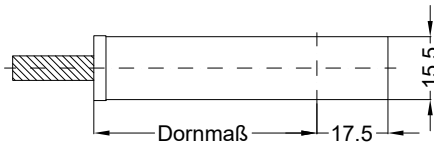

Situation
Riegel

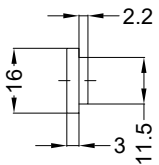

Lage
Schloss

Katalogdarstellung

Schloss: T-FF1662 .../D 92/... M2

Technische Änderungen vorbehalten!

