

Perspektive
 Schloss: T-FG1675 .../D 92/... R3

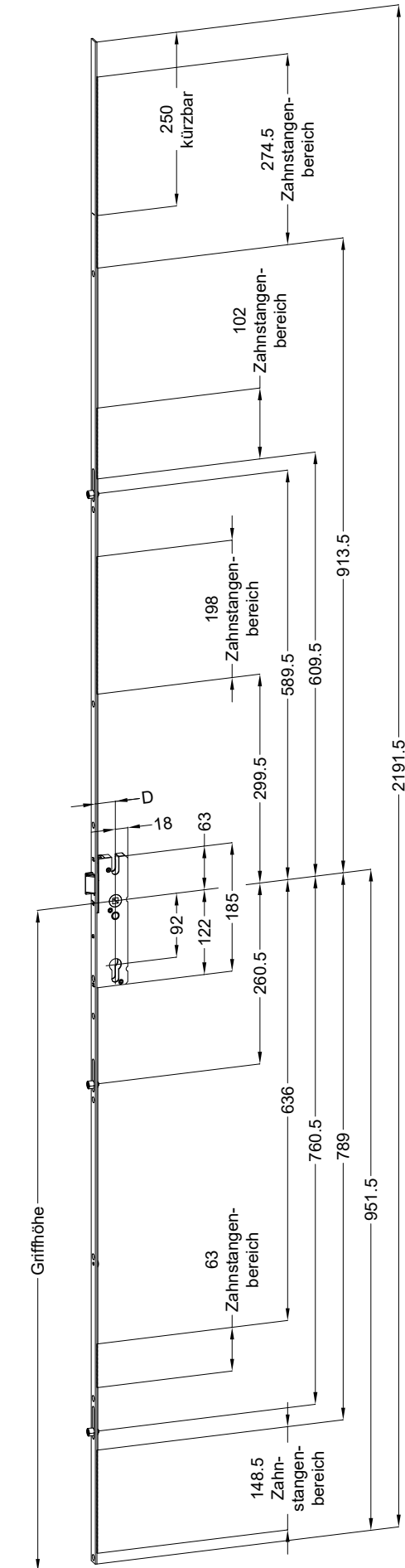

Technische Änderungen vorbehalten!

Schraublage
Schloss: T-FG1675 .../D 92/... R3

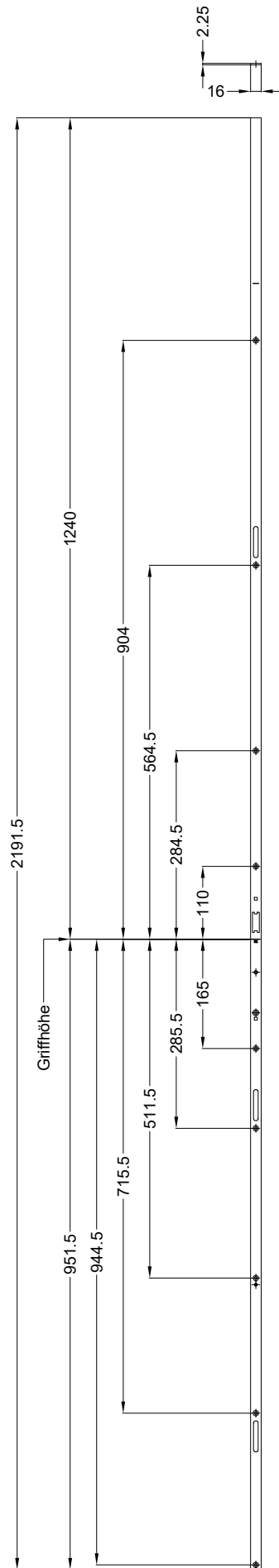

Ansichten

Schloss: T-FG1675 .../D 92/... R3

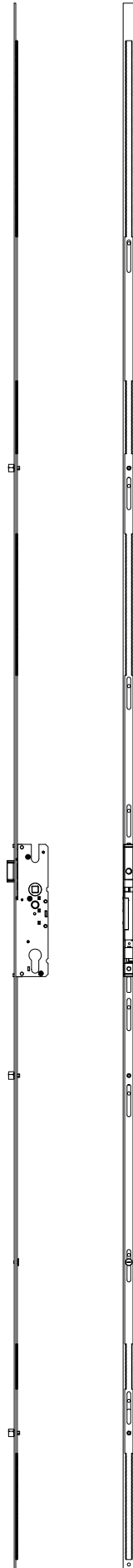

Technische Änderungen vorbehalten!

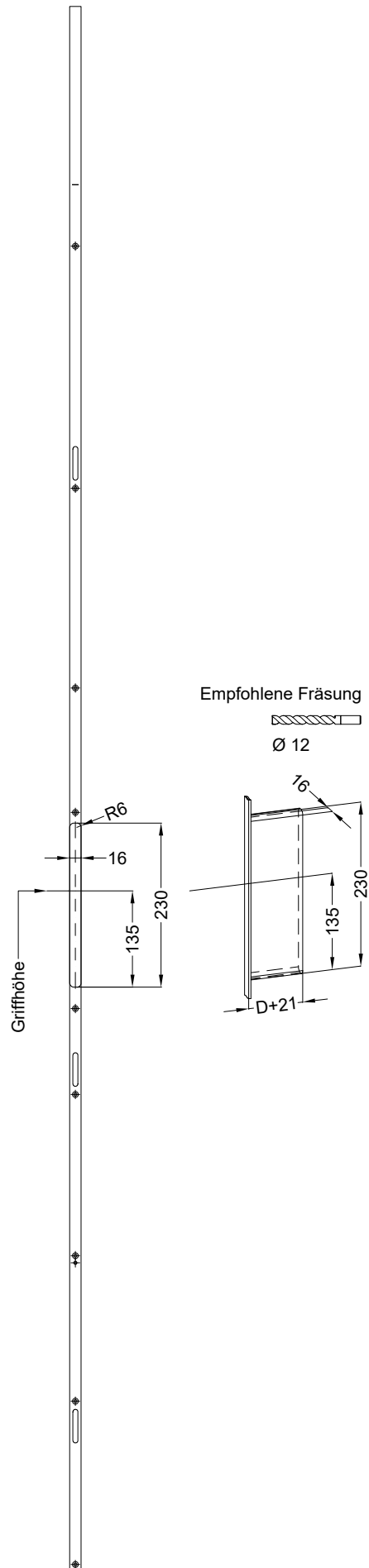

Allgemeine Vermaung

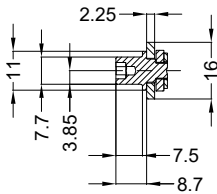

Frsmae

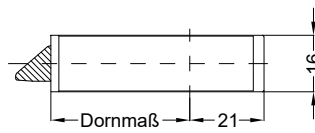
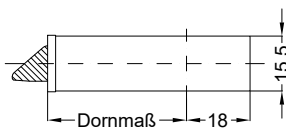

Situation
 Schliessbolzen
 Exzentrerschliebolzen SL

Situation
 Falle

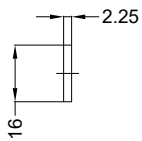

Lage
 Schloss

