

Schraublage
Schloss:

T-FG1674 .../D 92/... R3

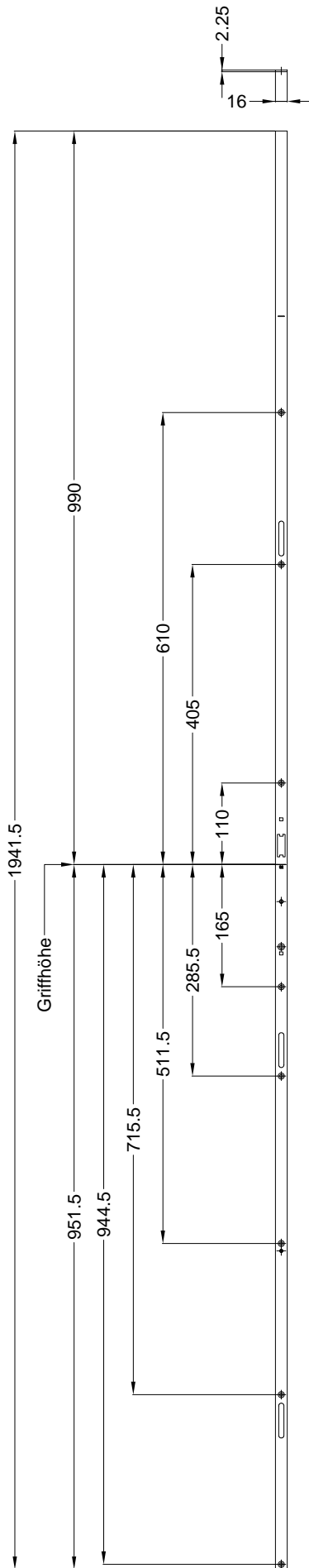

Technische Änderungen vorbehalten!

Ansichten
Schloss:

T-FG1674 .../D 92/... R3

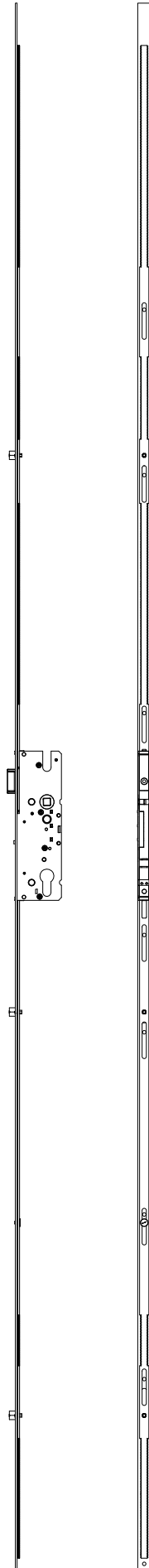

Technische Änderungen vorbehalten!

Fräsmaße
Schloss:

T-FG1674 .../D 92/... R3

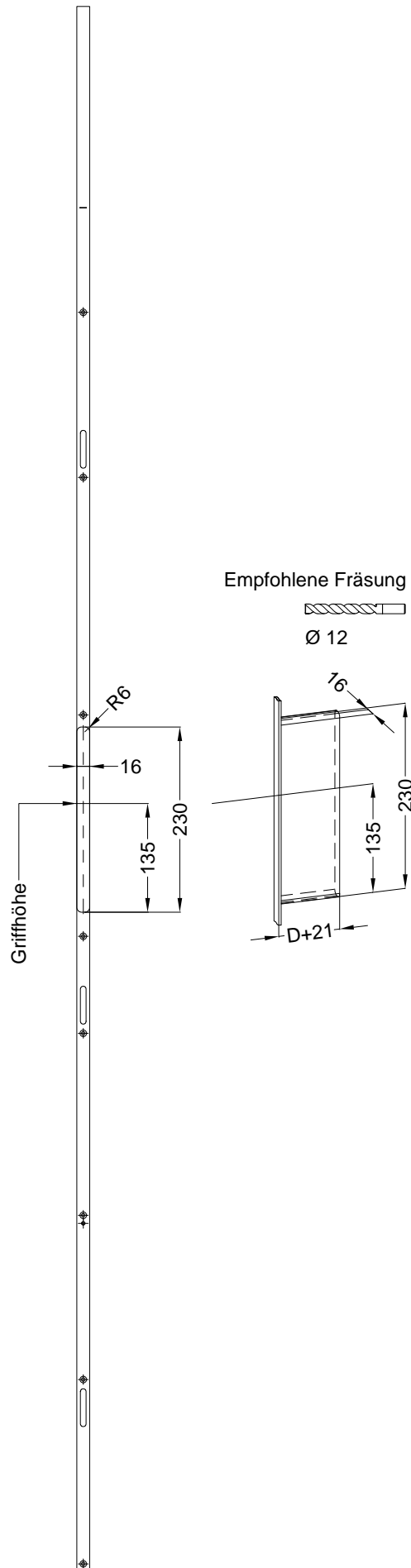

Allgemeine Vermaung

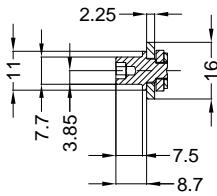

Frsmae

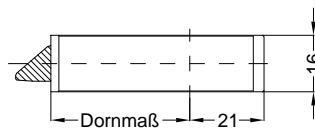
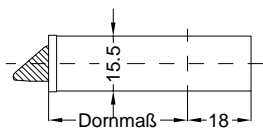

Situation
 Schliessbolzen
 Exzentrerschliebolzen SL

Situation
 Falle

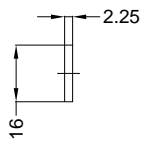

Lage
 Schloss

