

Ansichten
Schloss:

T-BM-U2293 .../D 92/... M2

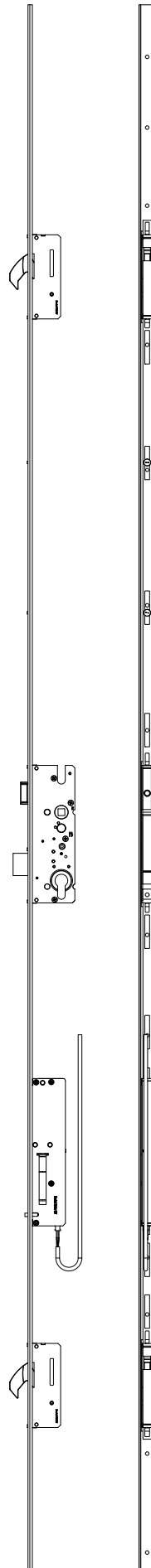

Technische Änderungen vorbehalten!

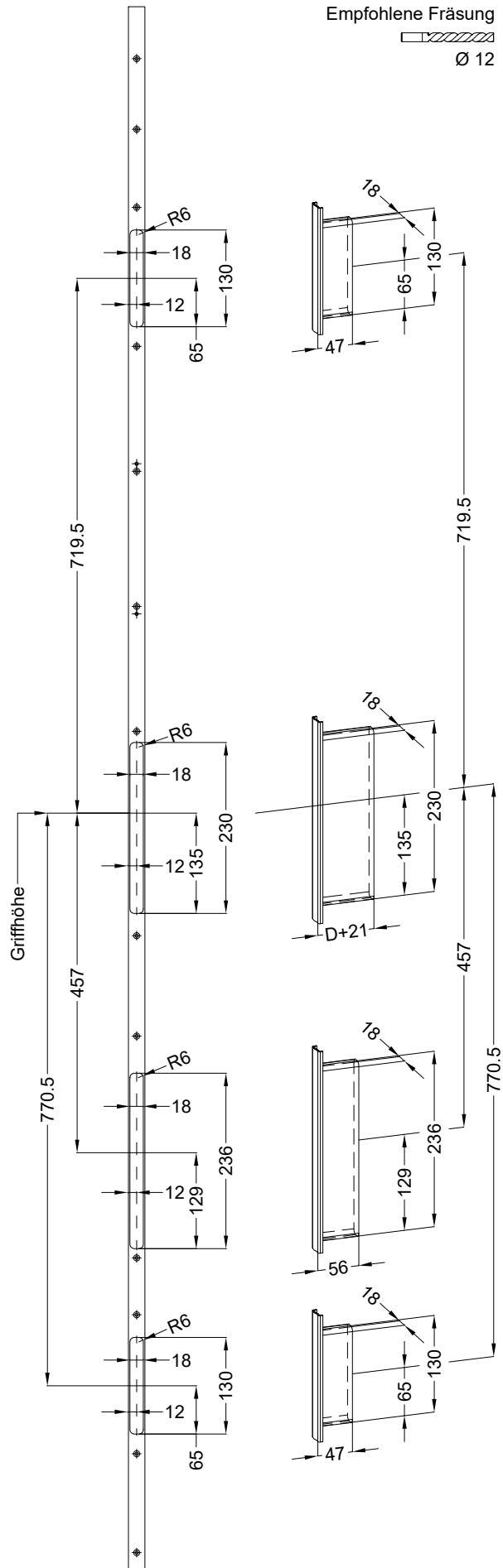

Allgemeine Vermaßung

Fräsmaße

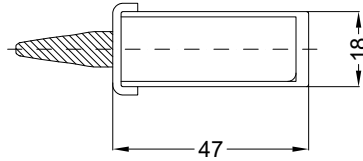
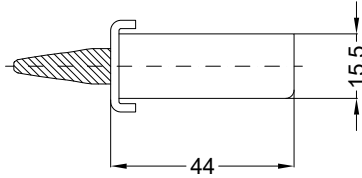

Situation
Schwenkriegel

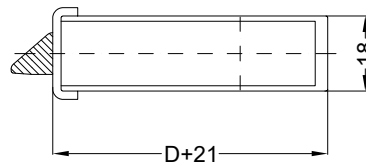
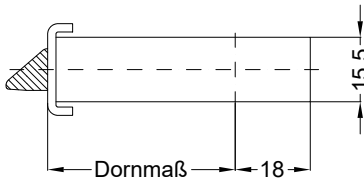

Situation
Falle

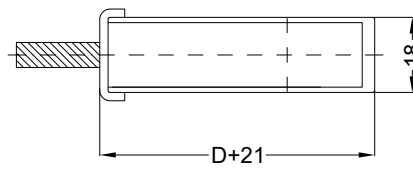
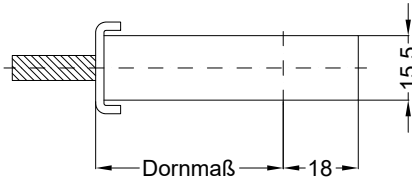

Situation
Riegel

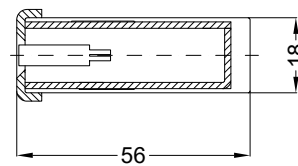
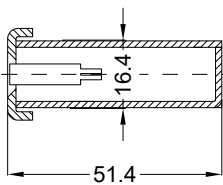

Situation
Motorkasten

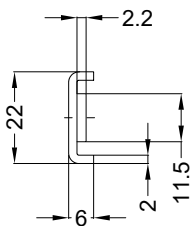

Lage
Schloss

Technische Änderungen vorbehalten!

