

## Aufnahmesegmente

1148.400

### Produktbeschreibung



#### Werkstoff

- Stahl, einsatzgehärtet, geschliffen

### Maßzeichnung

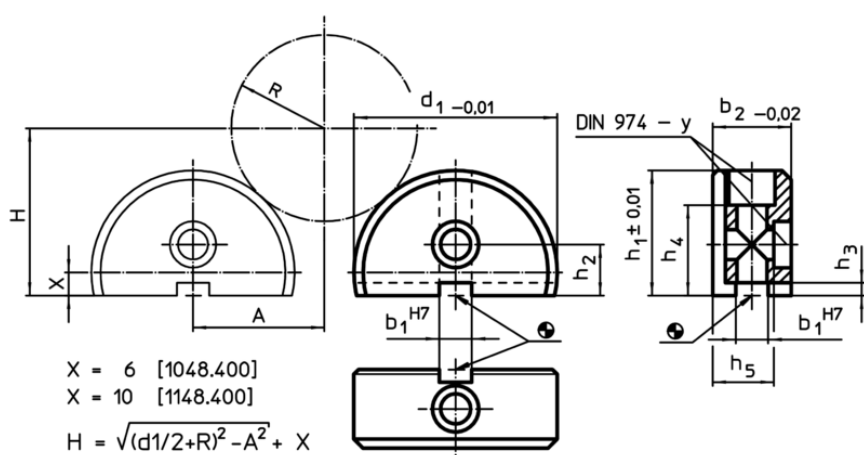

### Bestellinformationen

System	Abmessungen									für Schrauben [mm]	y [mm]	 [g]	Art.-Nr.
	b <sub>1</sub>	b <sub>2</sub>	d <sub>1</sub>	h <sub>1</sub>	h <sub>2</sub>	h <sub>3</sub>	h <sub>4</sub>	h <sub>5</sub>					
V70	14	34	88	54	22	6	39	26,5	M12	12	830	1148.400	

### Anwendungsbeispiel

