

Technische Änderungen vorbehalten!

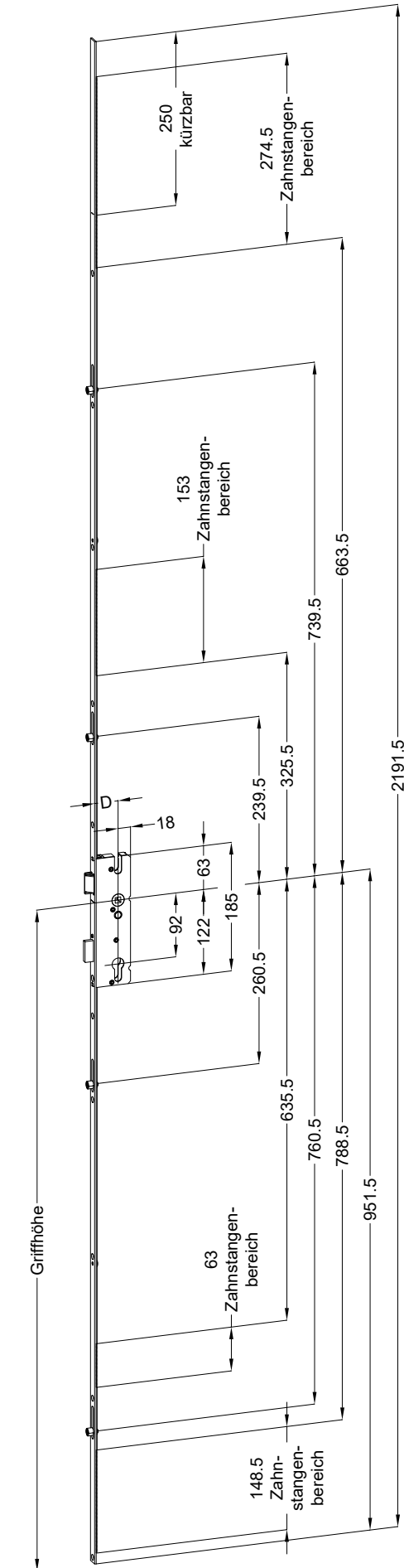

Schraublage
Schloss:

T-FG16175 .../D-12 92/... R4

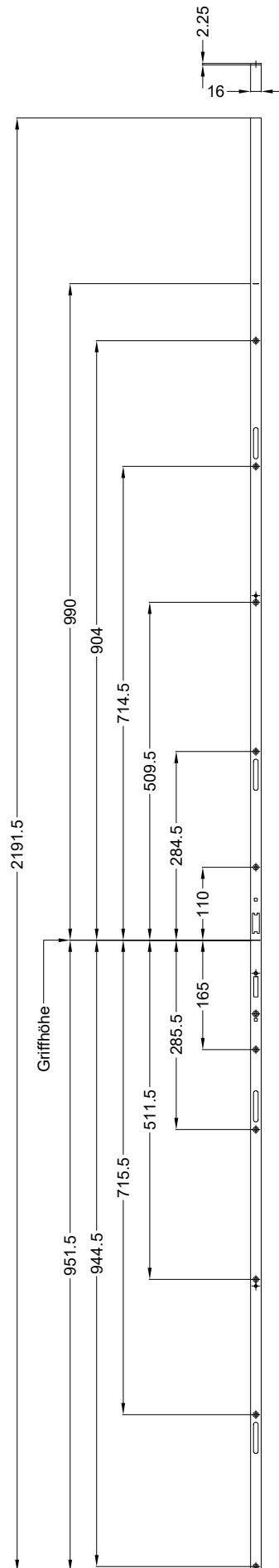

Technische Änderungen vorbehalten!

Ansichten
Schloss:

T-FG16175 .../D-12 92/... R4

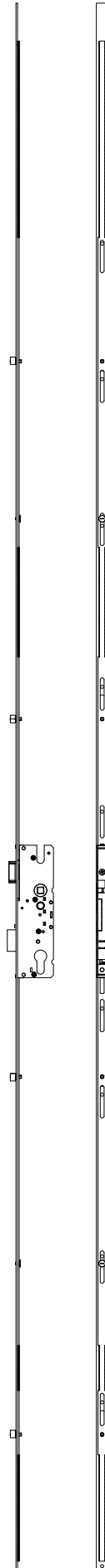

Technische Änderungen vorbehalten!

Fräsmaße
Schloss:

T-FG16175 .../D-12 92/... R4

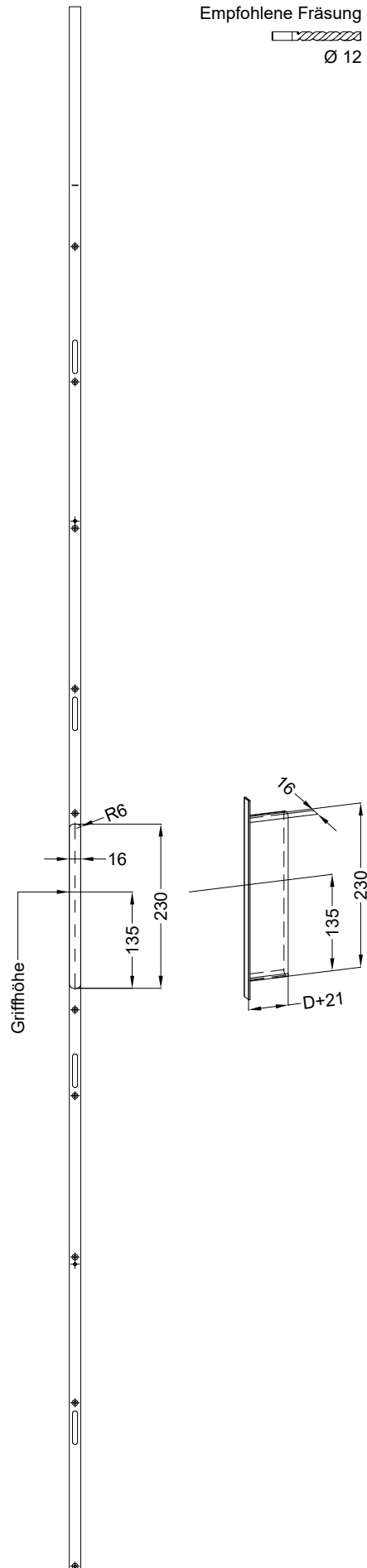

Allgemeine Vermaung

Frsmae

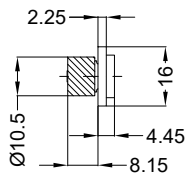

Situation
 Exzentrerschliessbolzen SL

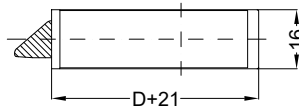
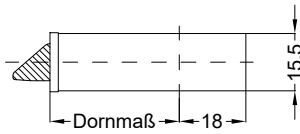

Situation
 Falle
 SK TT

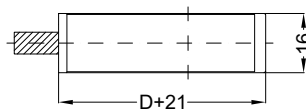
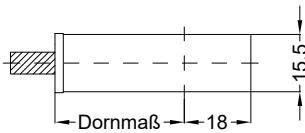

Situation
 Riegel
 SK TT

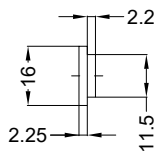

Lage
 Schloss

Katalogdarstellung

Schloss: T-FG16175 .../D-12 92/... R4



Technische Änderungen vorbehalten!

