

Perspektive
Schloss:

T-F1677 .../D 92/... R4

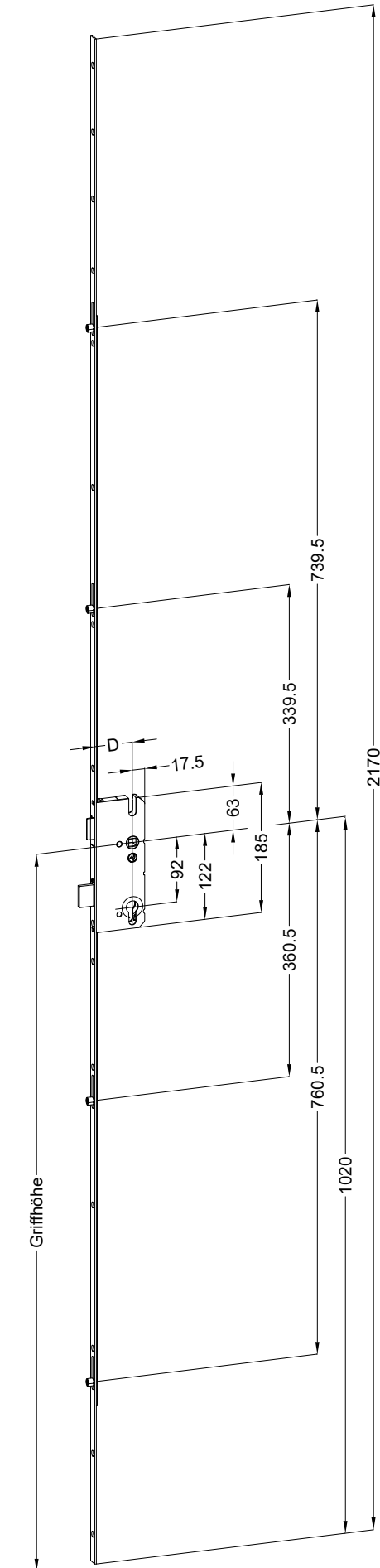

Technische Änderungen vorbehalten!

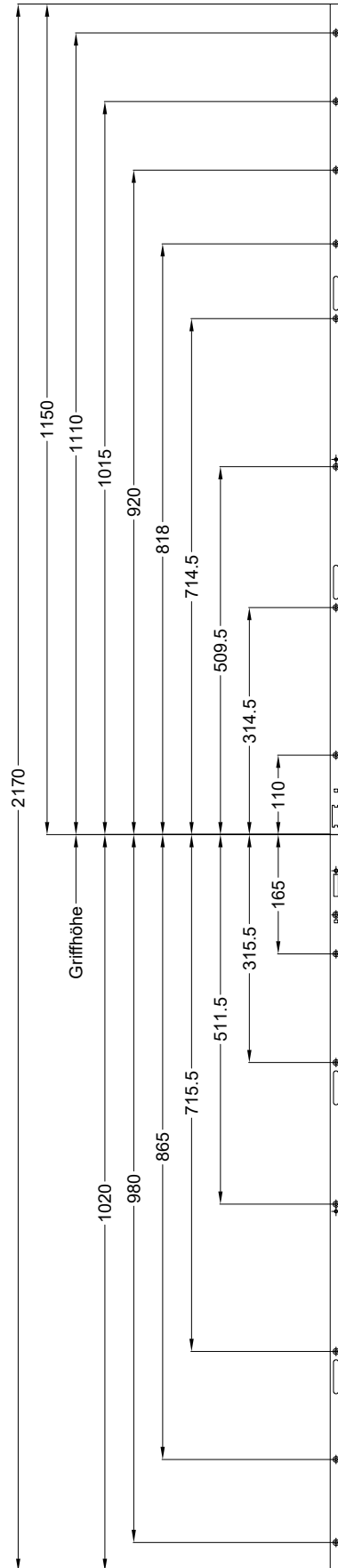
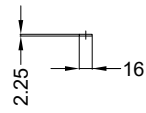

Ansichten
Schloss:

T-F1677 .../D 92/... R4



Technische Änderungen vorbehalten!

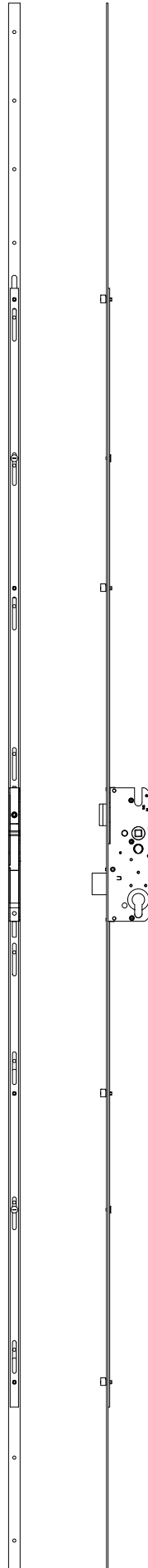

Fräsmaße
Schloss:

T-F1677 .../D 92/... R4

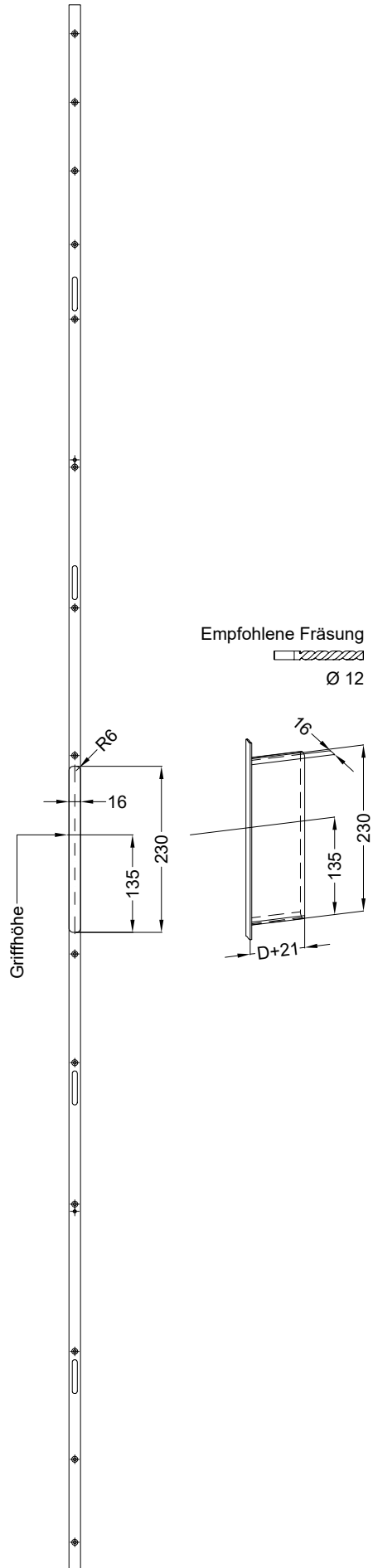

Allgemeine Vermaung

Frsmae

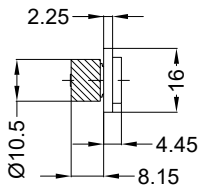

Situation
 Exzentrerschliebolzen

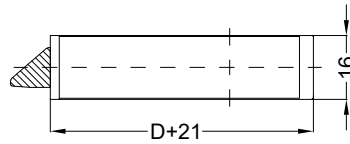
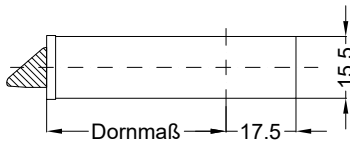

Situation
 Falle

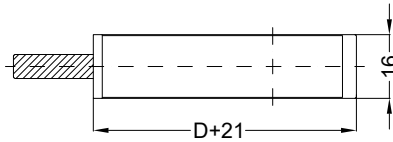
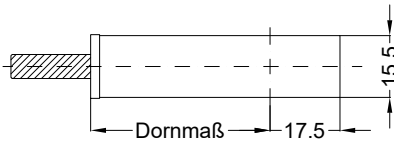

Situation
 Riegel

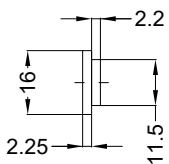

Lage
 Schloss

Katalogdarstellung

Schloss: T-F1677 .../D 92/... R4

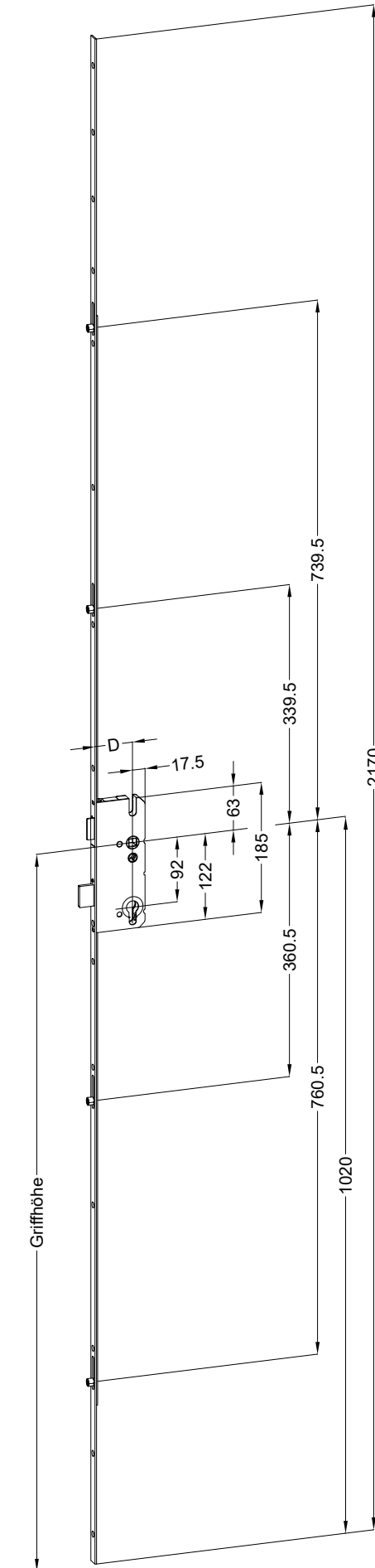

Empfohlene Fräsung
Ø 12

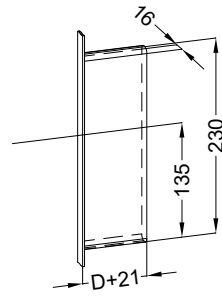

Technische Änderungen vorbehalten!