

Perspektive
Schloss:

T-AV3-UW24385 .../D A9 92/... M2 RS2

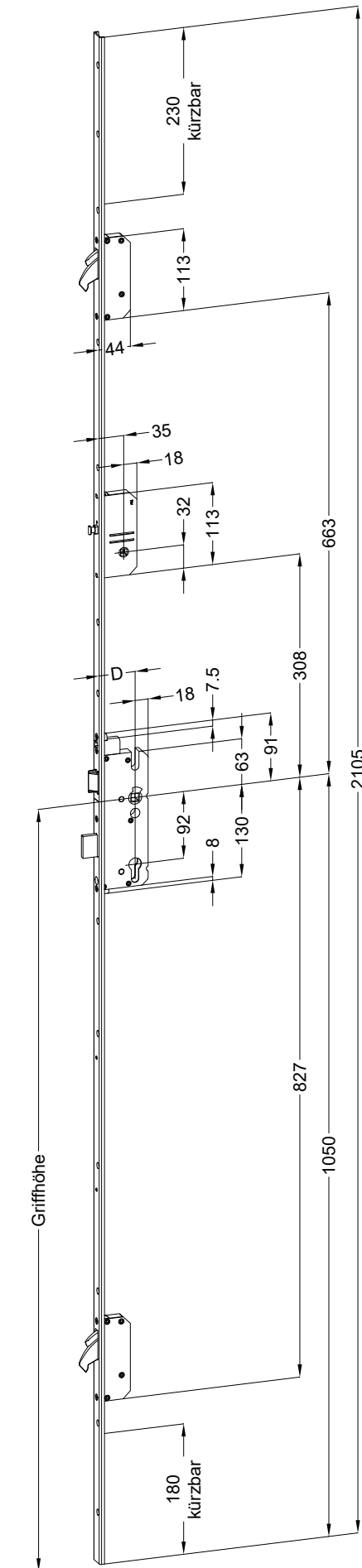

Technische Änderungen vorbehalten!

Schraublage
Schloss:

T-AV3-UW24385 .../D A9 92/... M2 RS2

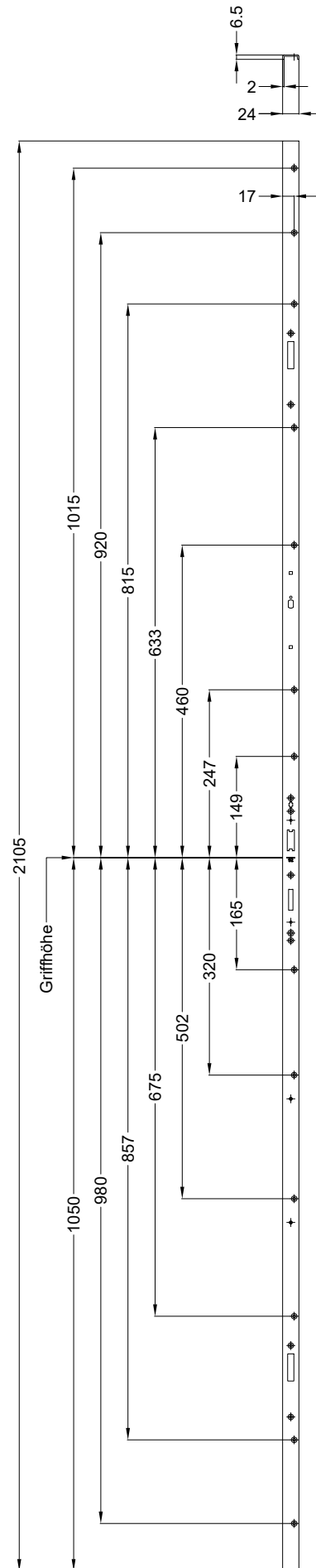

Technische Änderungen vorbehalten!

Ansichten
Schloss:

T-AV3-UW24385 .../D A9 92/... M2 RS2

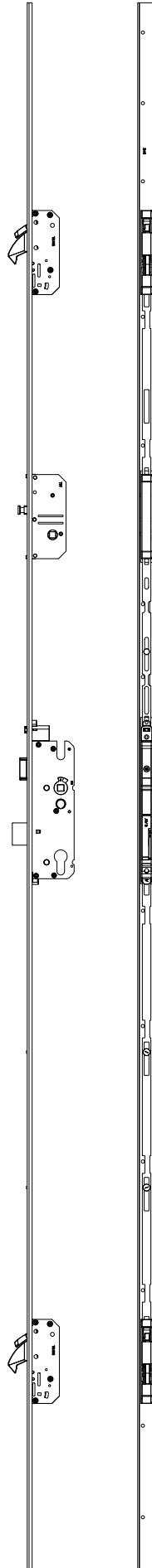

Technische Änderungen vorbehalten!

Allgemeine Vermaßung

Fräsmaße

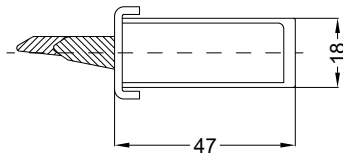
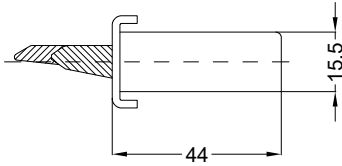

Situation
 Schwenkriegel
 TM AV3 SK RS

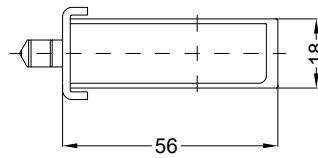
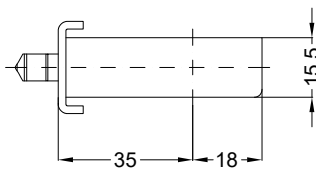

Situation
 Türwächter

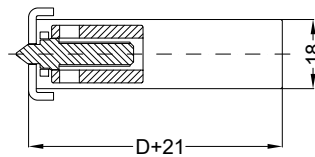
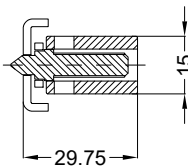

Situation
 Taststift
 SK AV3

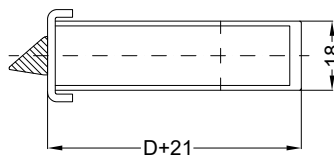
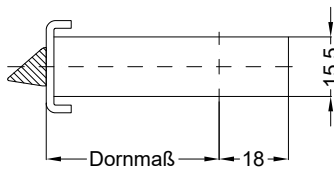

Situation
 Falle
 SK AV3

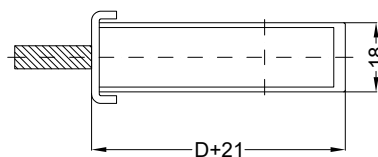
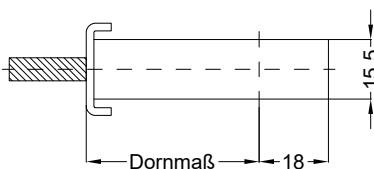

Situation
 Riegel
 SK AV3

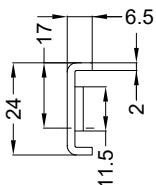

Lage
 Schloss

