

Ansichten
Schloss:

T-BM-U2460 .../D 92/... M2

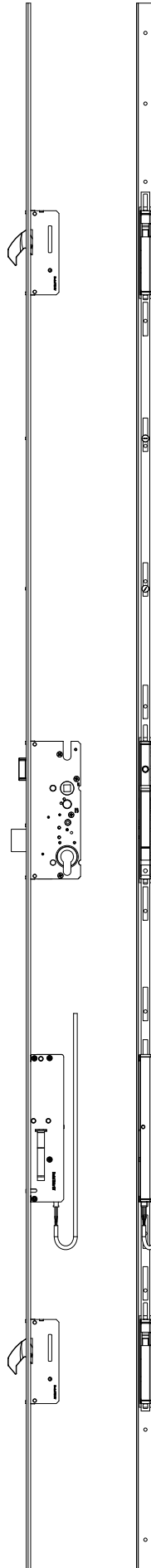

Technische Änderungen vorbehalten!

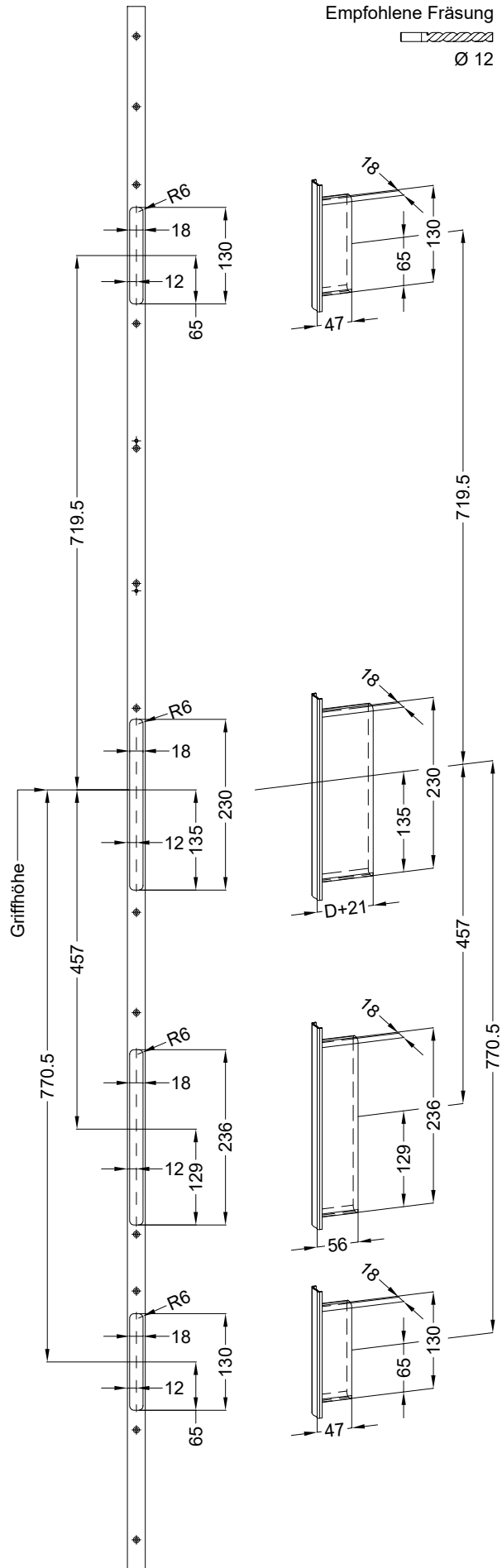

Allgemeine Vermaung

Frsmae

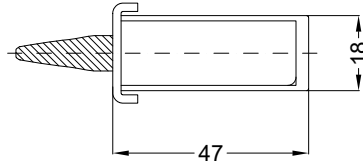
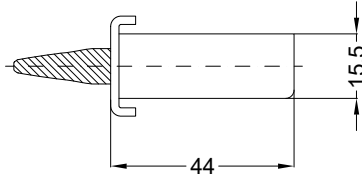

Situation
Schwenkriegel

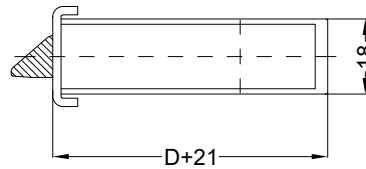
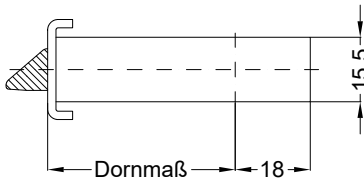

Situation
Falle

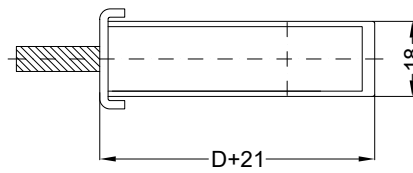
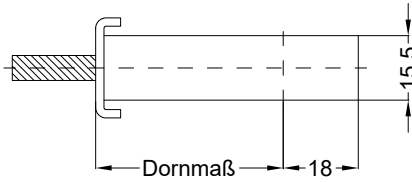

Situation
Riegel

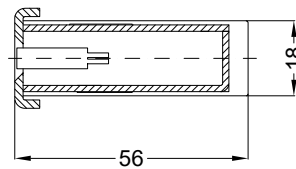
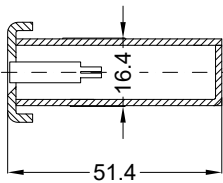

Situation
Motorkasten

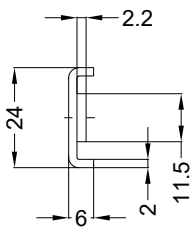

Lage
Schloss

Technische Änderungen vorbehalten!

