

Ansichten  
Schloss:

T-UG2407 .../D 92/... B2

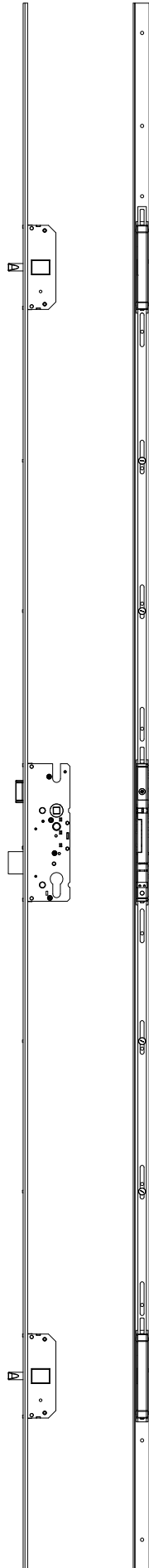

Technische Änderungen vorbehalten!

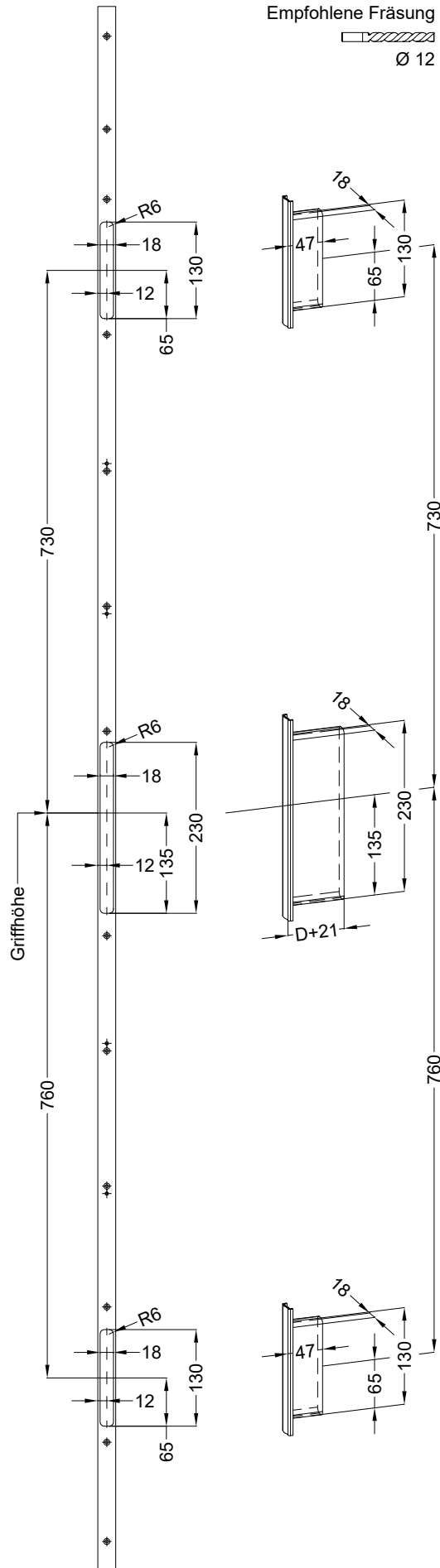

Allgemeine Vermaung

Frsmae

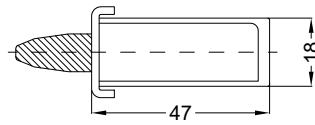
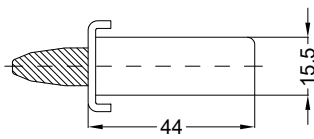

Situation  
 Bolzenschloss  
 G1 Bolzenkasten BV

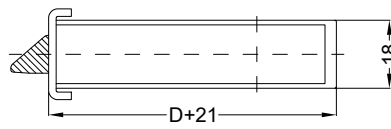
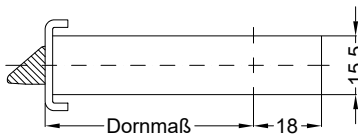

Situation  
 Falle  
 SK TT

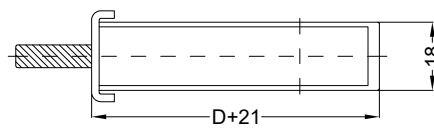
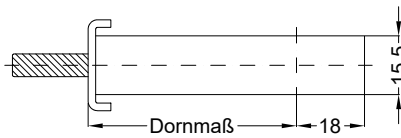

Situation  
 Riegel  
 SK TT

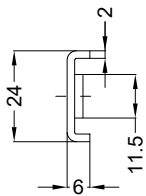

Lage  
 Schloss

Katalogdarstellung

Schloss: T-UG2407 .../D 92/... B2

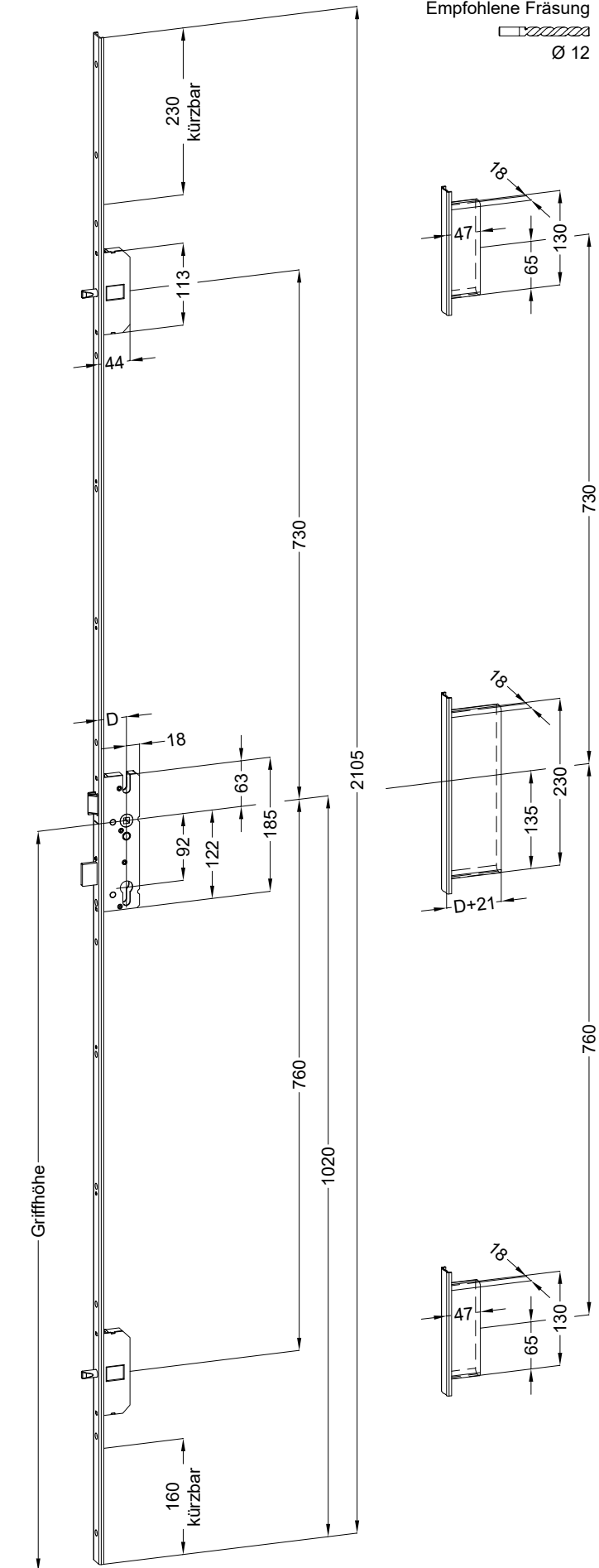

Technische Änderungen vorbehalten!