

Perspektive
Schloss:

T-F16036 .../D 92/... B2

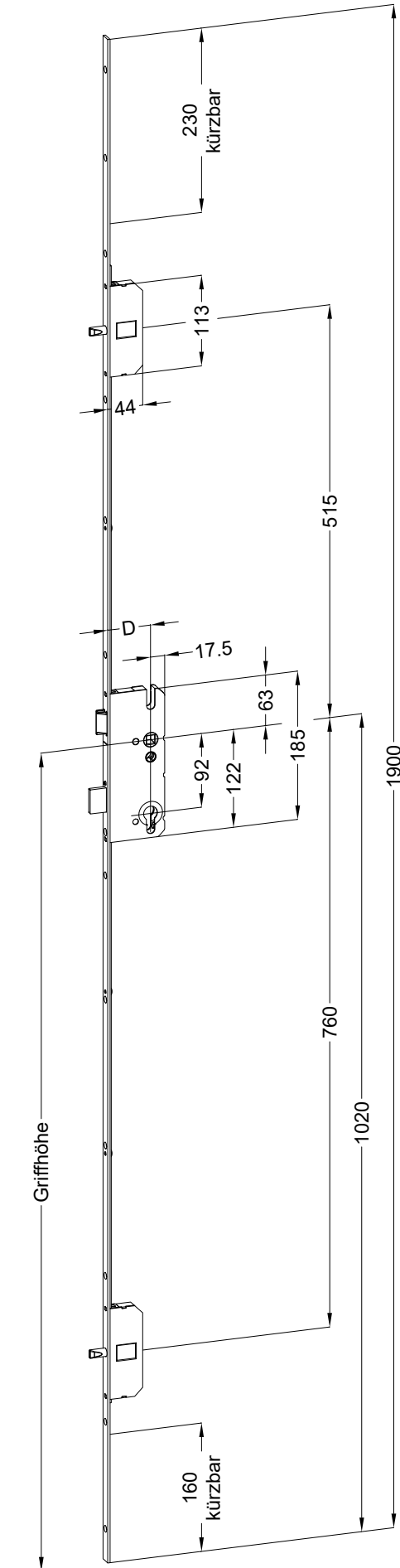

Technische Änderungen vorbehalten!

Schraublage

Schloss: T-F16036 .../D 92/... B2

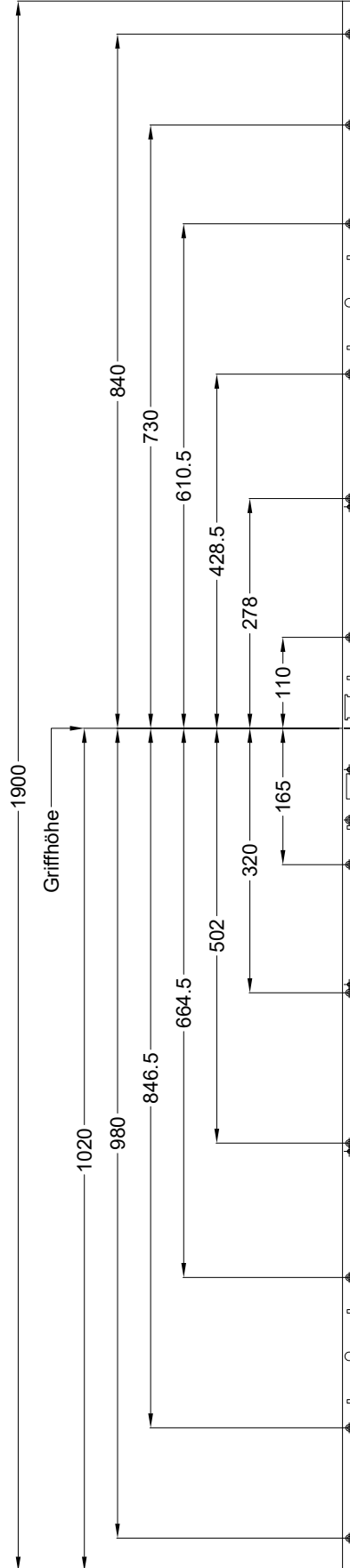
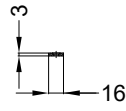

Technische Änderungen vorbehalten!

Ansichten
Schloss:

T-F16036 .../D 92/... B2

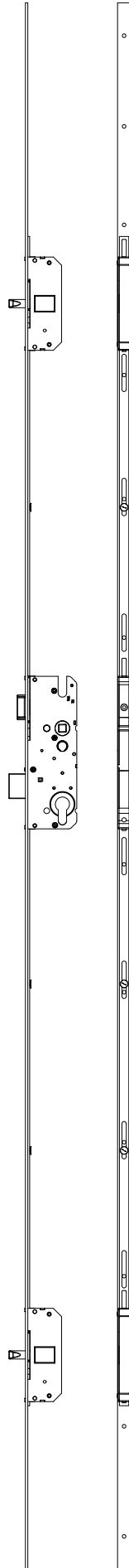

Technische Änderungen vorbehalten!

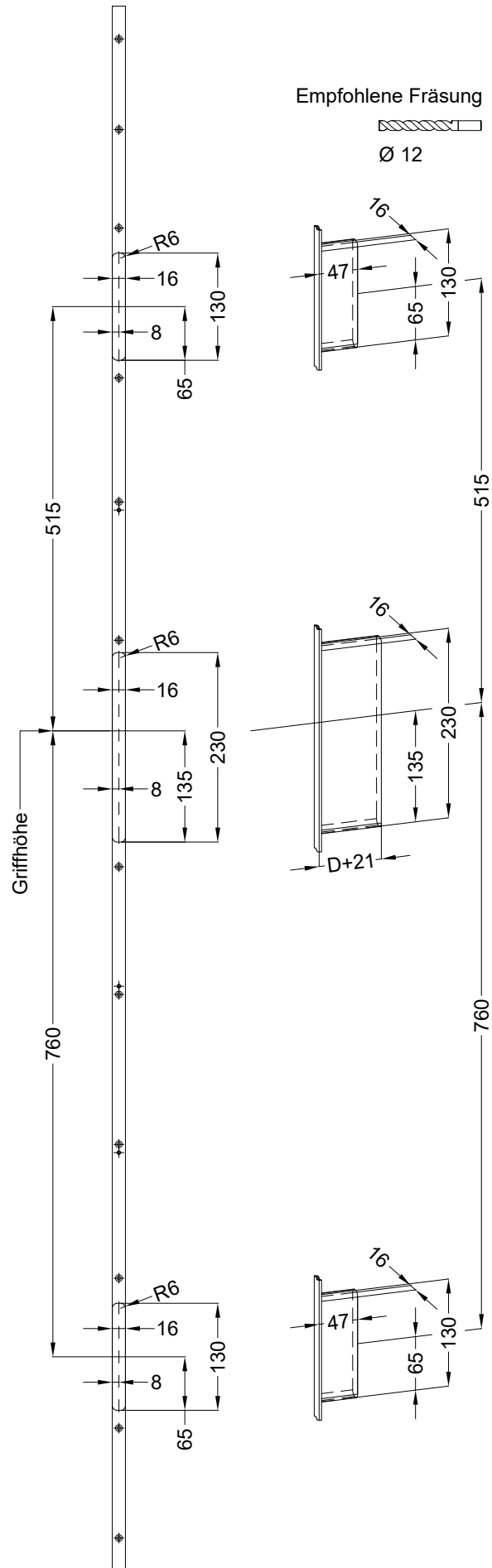

Allgemeine Vermaung

Frsmae

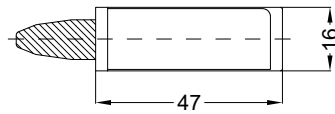
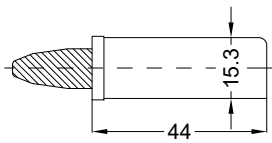

Situation
 Bolzenschloss

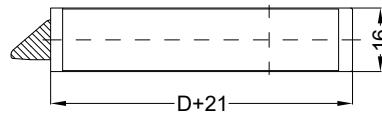
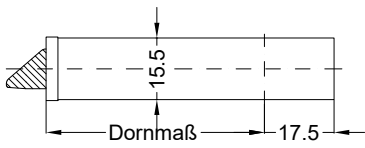

Situation
 Falle

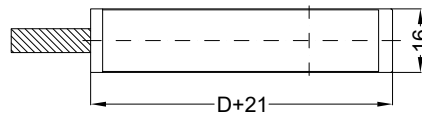
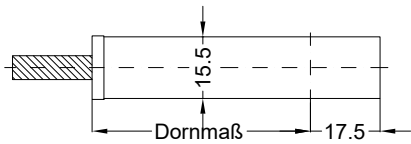

Situation
 Riegel

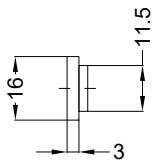

Lage
 Schloss

