

Ansichten
Schloss:

T-BM-F2069 .../D 92/... M2

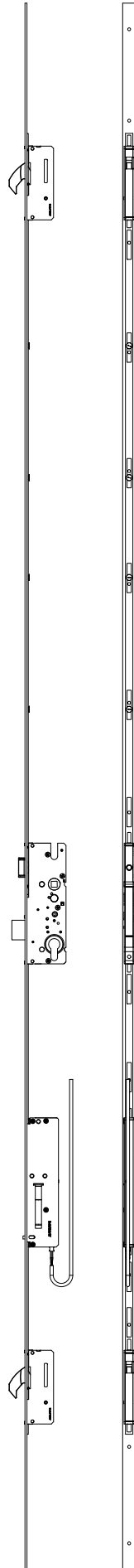

Technische Änderungen vorbehalten!

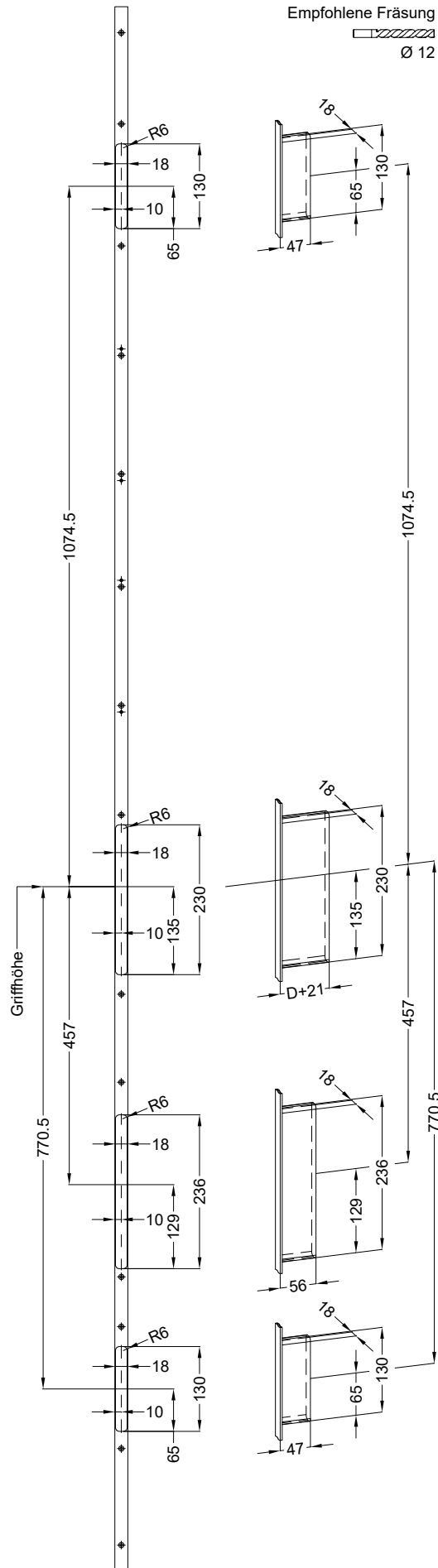

Allgemeine Vermaung

Frsmae

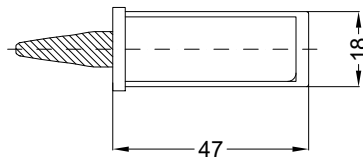
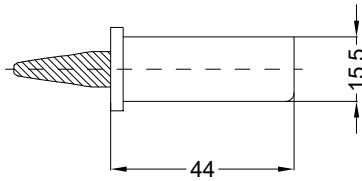

Situation
Schwenkriegel

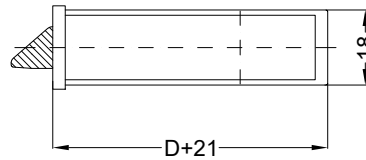
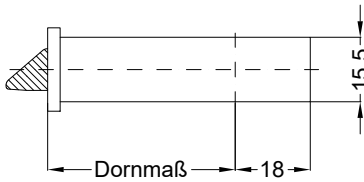

Situation
Falle

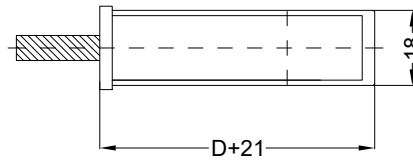
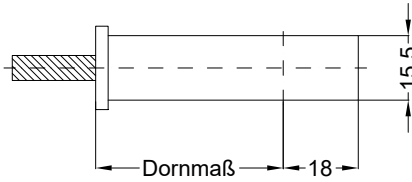

Situation
Riegel

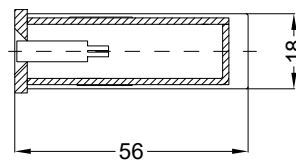
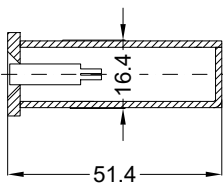

Situation
Motorkasten

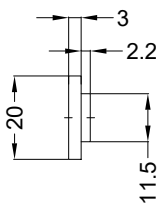

Lage
Schloss

Katalogdarstellung

Schloss: T-BM-F2069 .../D 92/... M2



Technische Änderungen vorbehalten!

