

Zwischenscheiben

1147.700

Produktbeschreibung



Werkstoff

- Stahl, einsatzgehärtet, geschliffen

Maßzeichnung

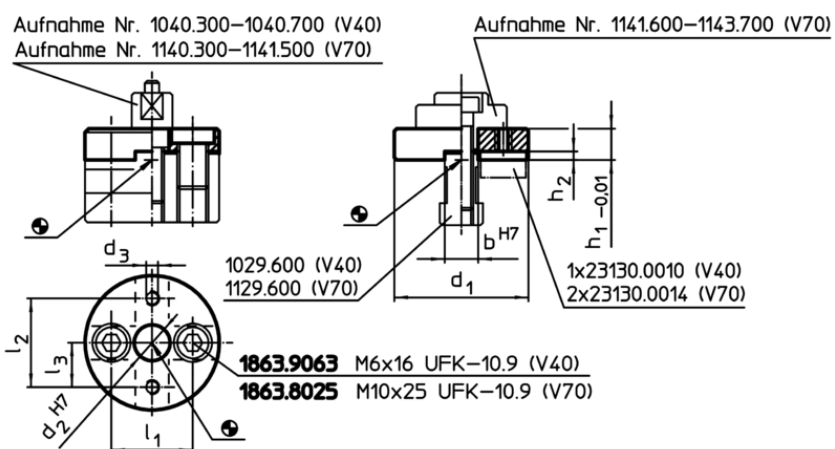

Bestellinformationen

| System | Abmessungen | | | | | | | | | [g] | Art.-Nr. |
|--------|----------------|----------------|----------------|----------------|----------------|----|----------------|----------------|------|-----|----------|
| | d ₁ | d ₂ | d ₃ | h ₁ | h ₂ | b | l ₁ | l ₂ | [mm] | | |
| V70 | 56 | 15 | M6 | 13 | 3,5 | 14 | 34 | 37 | | 160 | 1147.700 |

Anwendungsbeispiel

1863.8025 M10x25 UFK-10.9 (V70)
1863.9063 M6x16 UFK-10.9 (V40)

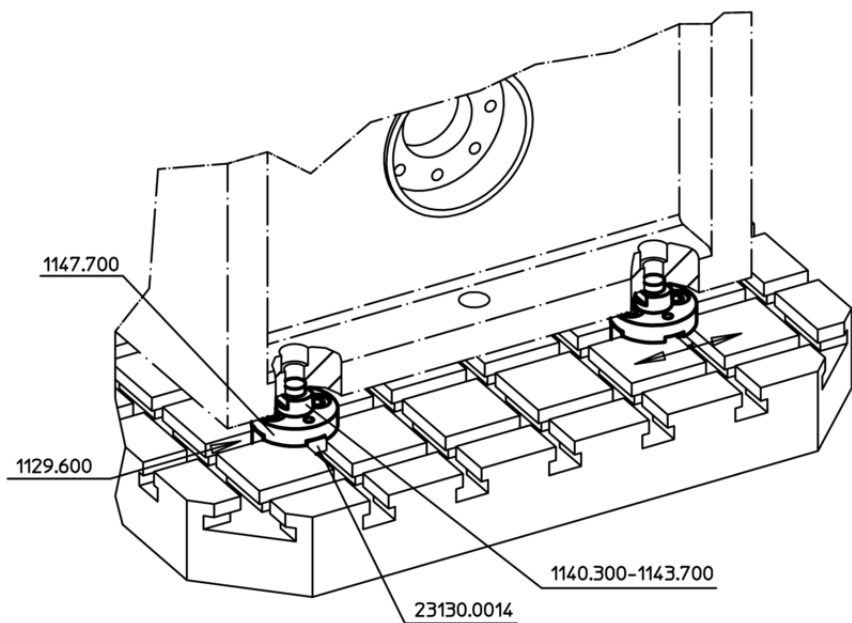
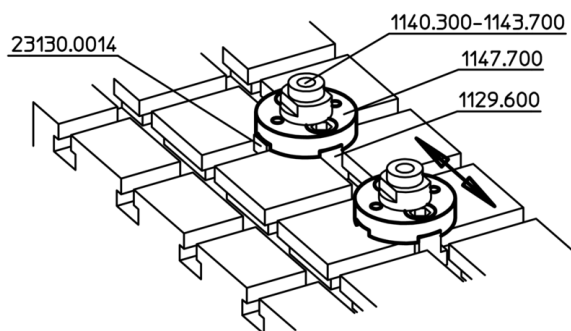
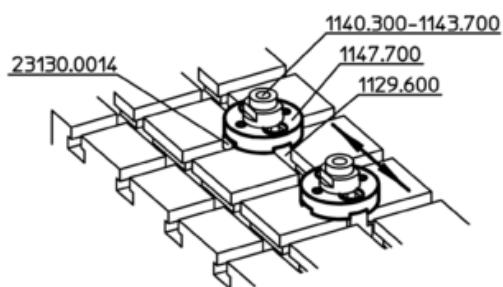
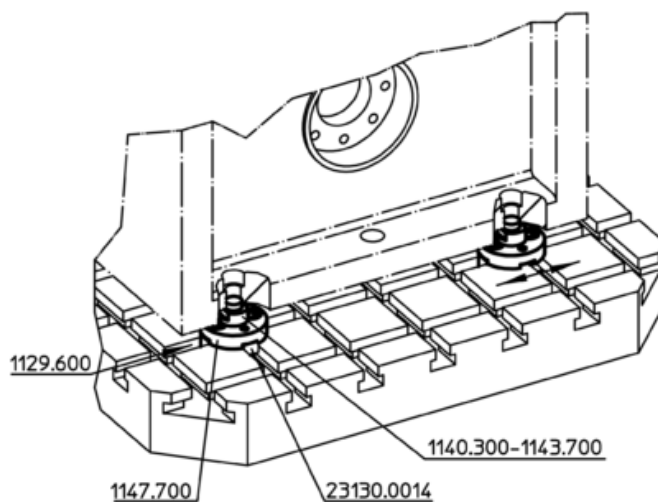
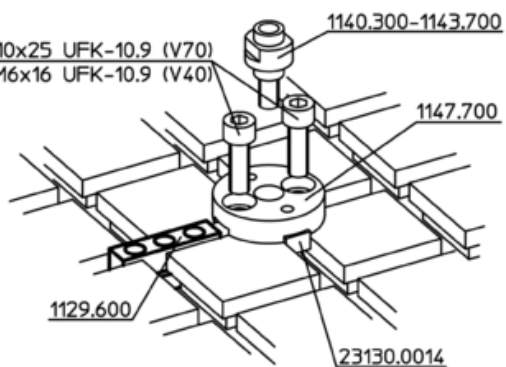

1863.8025 M10x25 UFK-10.9 (V70)

1863.9063 M6x16 UFK-10.9 (V40)

1140.300-1143.700

1147.700

1129.600

23130.0014

